

SPAN DP2 *Differential*

Pressure Transducer

Overview

The SPAN DP2 differential pressure (DP) transducer can measure line pressures up to 2,000 PSI with a turndown ratio of 15 to 1. Using Krystal Bond™ Technology, the SPAN DP2 contains no silicone oil, O-rings, or welds. This MEMS pressure sensor technology completely isolates the media to the pressure ports, thus eliminating contamination risk. The low strain level on the diaphragm results in accurate, repeatable measurements. The SPAN DP2 can be used to measure differential pressure across a filter, monitor level in a sealed or vented tank, or calculate flow across an orifice plate.

With its digital compensation, this series offers excellent linearity and performance over temperature. The electronics now offer a fail safe condition on the output signal. If the transducer were to experience a fault condition, the transducer can be programmed to rail the output signal to 10% below the minimum or 10% above maximum output signal to notify the user of an issue and protect the system from undesirable conditions. The SPAN DP2 also offers excellent flexibility in its configuration, allowing for a variety of wetted materials and pressure ports.



Benefits

- ASIC compensation
- Turndown capability
- Both or either pressure port can see full line pressure - **No expensive balancing valves required!**
- Line pressure up to 2,000 PSI
- Smart electronics with failure condition protection
- Wide variety of materials for a variety of media

Applications

- Aerospace
- Analytical Instruments
- Fuel Systems
- Hydraulics
- Hydrogen (316L only)
- Labs / Metrology
- Medical
- Military
- Test Stands
- Desalination Equipment (Inconel718 Recommended)

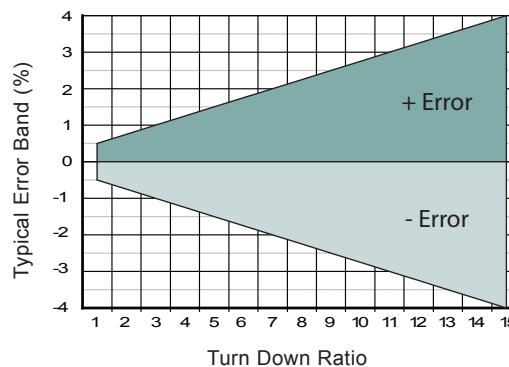

Performance @ 25°C (77°F)	
Total Error Band*	See Chart
Maximum Line Pressure	2,000 PSI (140 Bar)
Proof Pressure	2X Line pressure**
Burst Pressure	5X Line pressure
Pressure Cycles	> 100 Million
*Typical Values shown; Combined effects of Zero Offset, Span Tolerance, Thermal Zero, Thermal Span, Non-linearity, Repeatability and Hysteresis. **For higher line pressures, contact factory.	

Environmental Data	
Temperature	
Operating	-20 to 70°C (-4 to 158°F)
Storage	-50 to 125°C (-58 to 250°F)
Thermal Performance	
Compensated Temp. Range	-20 to 70°C (-4 to 158°F)
Other	
Shock: 100G, 10msec, 1/2 sine	EMI/RFI Rating: Yes
Vibration: 10G peak, 20 to 2000Hz	IP Class: IP-66; IP-67 Optional

Electrical Data				
Output	1-5V, 0-5V	1-6V, 1-10V, 0-10V	0.5-4.5V Ratiometric	4-20mA (three wire)
Excitation	10-28VDC	15-28VDC	5VDC, Regulated	10-28VDC
Current Consumption	< 15mA	< 15mA	< 15mA	-
Sampling Rate	200Hz	200Hz	200Hz	200Hz
Output Noise	< 1mV, RMS	< 1mV, RMS	< 1mV, RMS	< 1mV, RMS
Output Load	5k Ohms, min.	5k Ohms, min.	5k Ohms, min.	0-800 Ohms@10-28VDC
Reverse Polarity Protection	Yes	Yes	Yes	Yes

Ordering Information

DP2	F	01000	P	5	Y	0	0500	H	00
Series Type									
Process Connection									
A= 1/4" Male NPT									
B= 1/8" Male NPT									
C= 1/4" BSP Male									
E= 9/16-18 UNF Male (SAE 6)									
F= 7/16-20 UNF Male (SAE 4)									
K= 7/16-20 UNF Female (SAE4)									
Line Pressure									
Insert 5 -digit code from chart									
Pressure Unit									
P= PSI B= BAR, K= kg/cm2									
Outputs									
1= 0.5-4.5V ratiometric [5VDC Supply]					5= 0-10V				
2= 0-5V					6= 1-6V				
3= 1-5V					G= 1-10V				
4= 4-20mA									
Electrical									
A= 2 ft. (24 AWG) (0.6m)					I= DIN43650 A				
B= 4 ft. (24 AWG) (1.2m)					L= Conduit 2 ft. (0.6m)				
C= 6 ft (24 AWG)					R= 6 Pin Bendix				
D= 10 ft (24 AWG)					Y= M12x1 Eurofast				
E= Mini DIN 43650C									
Wetted Material									
0= 17-4PH 1= 316L 2= Inconel718 (contact factory for availability)									
Differential Pressure Range									
Insert 4-digit code from Chart									
Fail Condition									
N= Not Specified			H= Fail High			L= Fail Low			
Options									
Kem= KemX Barrier									

		Line Pressure*						
		50	100	300	500	1000	2000	
		CODE	00050	00100	00300	00500	01000	02000
Differential Pressure Range* (PSID)	10	0010	✓	✓				
	20	0020	✓	✓	✓			
	50	0050		✓	✓	✓		
	75	0075		✓	✓	✓	✓	
	100	0100		✓	✓	✓	✓	
	150	0150			✓	✓	✓	
	200	0200			✓	✓	✓	✓
	300	0300			✓	✓	✓	✓
	500	0500				✓	✓	✓
	750	0750					✓	✓
1000	1000						✓	
2000	2000						✓	

*Other ranges available; contact factory.

Dimensional Data

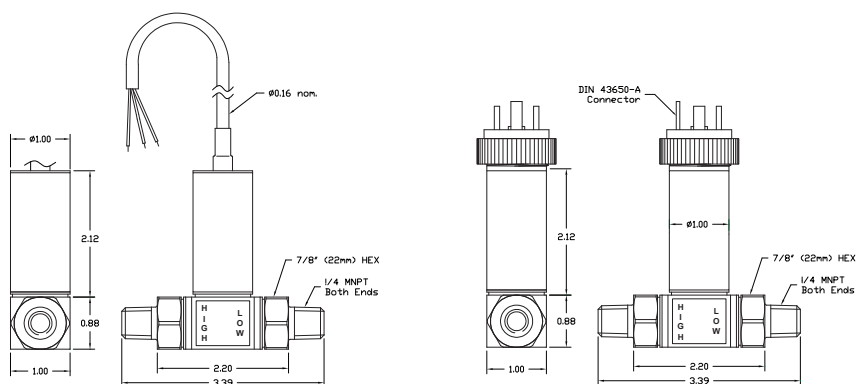

Warranty

Workmanship - SPAN pressure transmitters have a limited one-year warranty to the original purchaser. SPAN will replace or repair, free of charge, any defective transmitter. This warranty does not apply to any units that have been modified; misused, neglected or installed where the application exceeds published ratings.

Installation/Applications - The purchaser is responsible for media compatibility, functional adequacy, and correct installation of the transmitter.

SPAN4200 Industrial Grade Panel Mount

Stainless Steel Media Isolated Pressure Sensor

Overview

The **SPAN OEM Pressure Sensor** can be constructed as a amplified voltage output pressure transducer or 4-20mA loop powered pressure transmitter. The 4200 covers a wide variety of applications that require rugged construction, high cycle life, as well as media compatibility to deliver outstanding and long-term performance.

Krystal Bond™ Technology is the foundation of the 4200. This leading **MEMS** technology gives the flexibility to be used in virtually any OEM application. Whether measuring hydraulic pressure in a manifold or corrosive media such as sea water or hydrogen the 4200 pressure sensor provides a thick diaphragm to maintain long-term stability and use.

Benefits

- High Strength Stainless Steel Construction and UL/cUL 508 Approved
- No Oil, Welds or Internal O-rings
- Wide Operating Temperature Range and ranges up to 10,000 PSI
- Low Static and Thermal Errors and EMI/RFI Protection
- Unparalleled Price and Performance
- Compatible with Wide Range of Liquids and Gases
- Simple Installation for Panel Builders

Applications

- Control Panels
- Industrial OEM Equipment
- Hydraulic Systems
- HVAC/R Equipment
- Data Loggers
- Pneumatics



Environmental Data

Temperature

Operating	-40 to 85°C (-40 to 185°F)
Storage	-40 to 100°C (-40 to 212°F)

Thermal Limits

Compensated Range	0 to 55°C (30 to 130°F)
TC Zero	<±1.5% of FS
TC Span	<±1.5% of FS

Other

Shock	100G, 11 msec, 1/2 sine
Vibration	10G peak, 20 to 2000 Hz.
EMI/RFI Protection:	Yes
Rating:	IP-66 (housing only)

Performance @ 25°C (77°F)

Accuracy*	< ±0.5% BFSL
Stability (1 year)	±0.25% FS, typical
Over range Protection	2X Rated Pressure
Burst Pressure	5X or 20,000 PSI (whichever is less)
Pressure Cycles	> 100 Million

* Accuracy includes non-linearity, hysteresis & non-repeatability

Electrical Data

Output	4-20mA	1-5VDC	0.5-4.5V Ratiometric
Excitation	10-28VDC	10-28VDC	5VDC, regulated
Output Impedance	>10k Ohms	<100 Ohms, Nominal	<100 Ohms, Nominal
Current Consumption:	20mA, typical	<10mA	<10mA
Bandwidth	(-3dB): DC to 250 Hz	(-3dB): DC to 1kHz	(-3dB): DC to 1kHz
Output Noise:	-	<2mV RMS	<2mV RMS
Zero Offset:	<±1% of FS	<±1% of FS	<±1% of FS
Span Tolerance:	<±2% of FS	<±1.5% of FS	<±1.5% of FS
Output Load:	0-800 Ohms@10-28VDC	10k Ohms, min	10K Ohms, min
Reverse Polarity Protection	Yes	Yes	Yes

Ordering Information

SPAN4200 J 00100 P 4 A 0 000

Series Type

Configuration Interface

A= 1/4" NPT Male

Pressure Range

Insert 5-digit pressure range code below

Pressure Unit

P= PSI

Outputs

1= 0.5-4.5V ratiometric

3= 1-5V

4= 4-20mA (2 wire loop powered)

Electrical*

D= 10 ft. (3.0m)

E= Mini DIN 43650

Z= DT04 Deutsch

Wetted Material

0= 17-4PH

Options

Kem= KemX Barrier

Pressure Ranges*

PSIG Measurement Range	Pressure Range Code	BARG Measurement Range	Pressure Range Code
-14.7 to 25**	V0025**	-1 to 2**	V0002**
0-25	00025	0-2	00002
0-50	00050	0-5	00005
0-100	00100	0-7	00007
0-150	00150	0-10	00010
0-200	00200	0-20	00020
0-250	00250	0-35	00035
0-500	00500	0-50	00050
0-1,000	01000	0-70	00070
0-2,500	02500	0-100	00100
0-5,000	05000	0-250	00250
0-7,500	07500	0-350	00350
0-10,000	10000	0-500	00500
		0-700	00700

*Typical ranges. All ranges between 0-25 PSI and 0-10,000 PSI available.
 **Compound ranges up to -14.7 to 500 PSI available. Please consult factory.

Dimensional Data

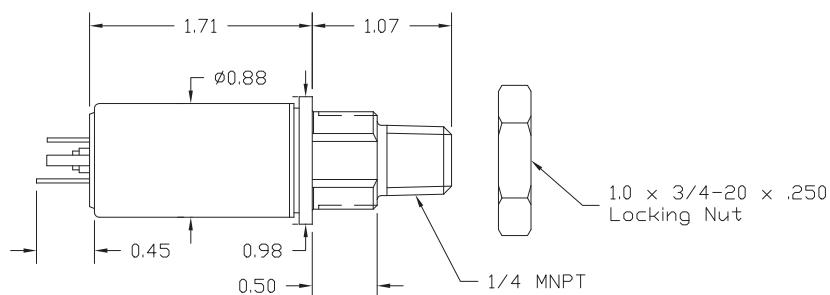

Warranty

Workmanship - SPAN pressure transmitters have a limited one-year warranty to the original purchaser. SPAN will replace or repair, free of charge, any defective transmitter. This warranty does not apply to any units that have been modified; misused, neglected or installed where the application exceeds published ratings.

Installation/Applications - The purchaser is responsible for media compatibility, functional adequacy, and correct installation of the transmitter.